

MY-HITE ADJUSTABLE TABLE

STRAIGHT C LEG BASE

Model Number : FSQAHBC

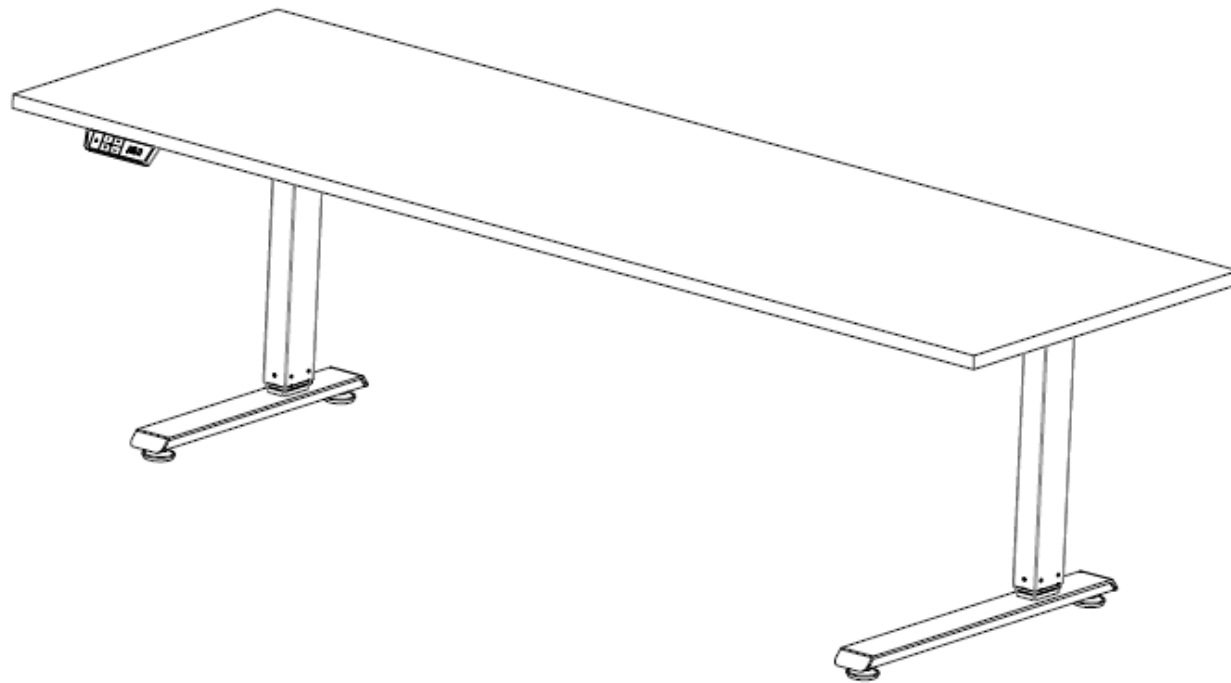

Please Read Instructions Before Use
ASSEMBLY INSTRUCTIONS



ALL
WORKSTYLES
WELCOME

Thank you for choosing Friant. We appreciate the trust and confidence you have placed in us and are committed to providing you the best possible product.

» **Introduction**

Friant offers a comprehensive line of office furniture for every space and requirement, now including My-Hite, a height adjustable table that allows for standing or sitting while working.

» **User Notes**

1. As with all power-operated products, please follow instructions and handle with care.
2. When moving My-Hite tables, please lift the tables, do not drag them.
3. Check that the load on the table does not exceed limits (220lbs for straight, 330lbs for corner).
4. Table should be level and aligned at all times.

Tools Needed



Single Sided Wrench



Socket Head Wrench



Electric Drill

Important:

When placing table in final location, be sure there is ample room for adjustment around ALL sides, and at the highest (50”) and lowest (24.5”) points the table can reach. Make sure table will not come into contact with any fixed objects (fixed tops, storage, shelving, etc.) while adjusting.

WARNING:

FAILURE TO FOLLOW THE ASSEMBLY INSTRUCTIONS IN THIS MANUAL CAN RESULT IN PRODUCT DAMAGE, OR PERSONAL INJURY.

Friant & Associates, LLC does not assume any responsibility for product that is altered in any way.

1









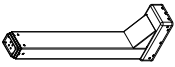

1. Read instructions carefully. Check that no parts are missing.

2

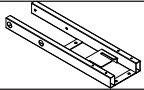

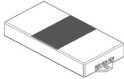
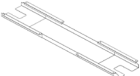
2. Carefully identify each component, especially those that are similar. The most common mistake is mixing up the order and placement of parts.

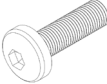
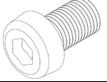
Parts List

PART#		NAME	PIECES
A		Side Bracket	2
B		Column Leg	2
C		Pad	1
D		Crossbeam	2
E		Center Rails	2
F		Control Panel	1
G		Control Box	1
H		Telescopic Cover Plate	1
I		Connector Wires	
J		Feet	2
K		Socket Button Head Bolt M6*20mm	8
L		Socket Button Head Bolt M6*12mm	16
M		Wire Manager	3
N		Truss Head Screw M5*20mm	26

Installation Steps

Step 1: Place worksurface finished side down on a blanket.

Step 2: Insert **A** side bracket into **D** crossbeam assembly. Repeat with other side bracket.

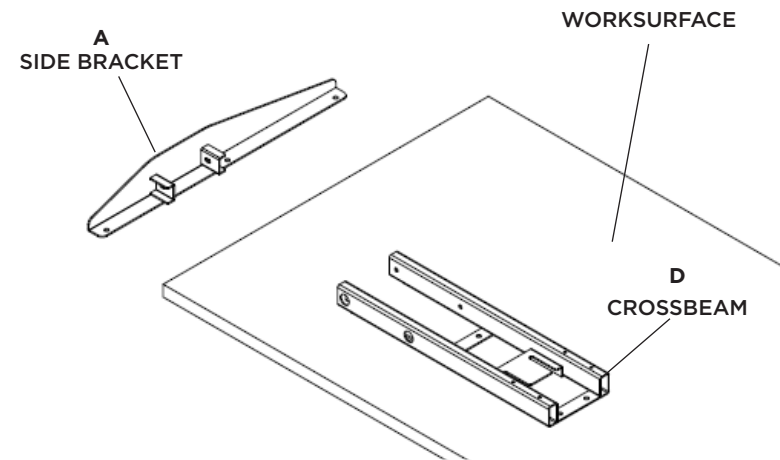

Step 3: Insert **C** pad under **B** leg during assembly process for proper spacing.

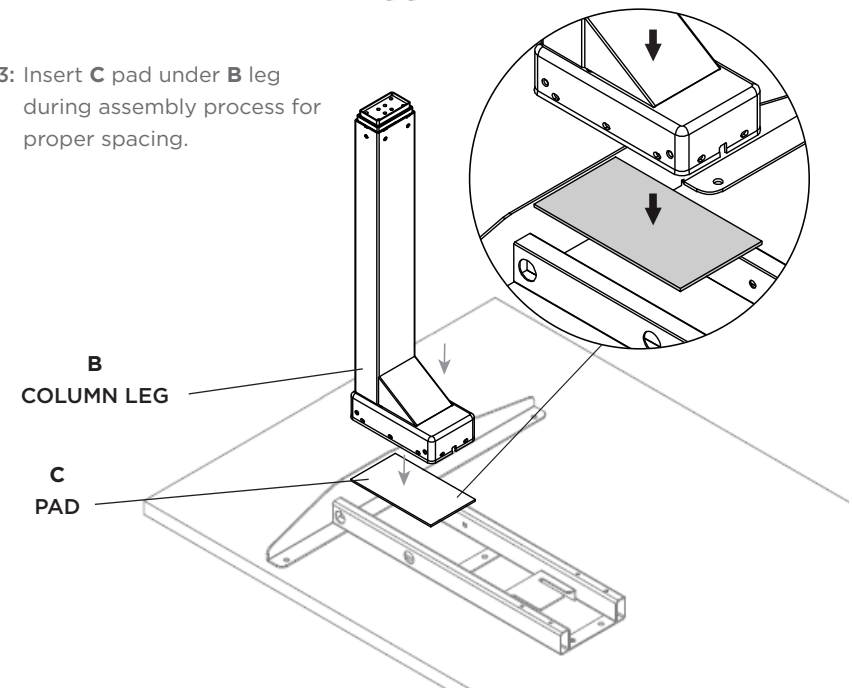

Installation Steps

Step 4a: Use 4 socket button head bolts, M6*12mm to attach side bracket, column leg and crossbeam together as shown in detail. Repeat with other leg.

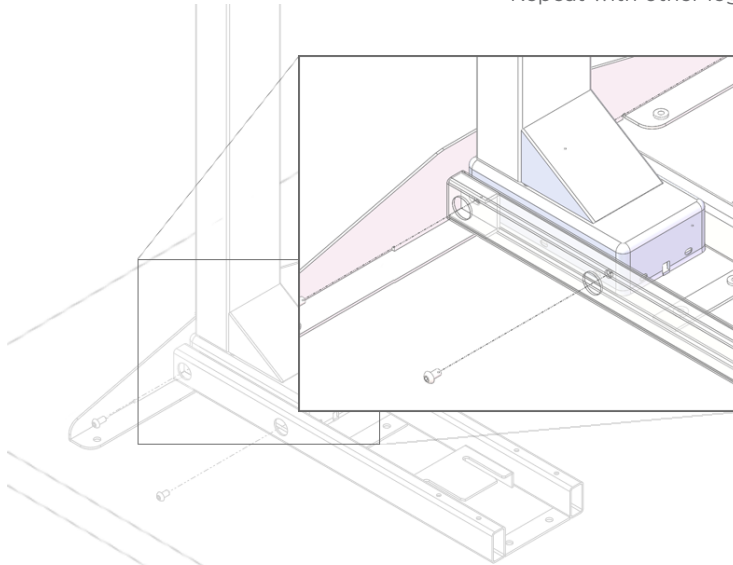

Step 4b: Remove **C** pad after leg installation, then reuse for assembly of other leg(s) repeating steps 3 & 4.

Remove pad when done.

Step 5: Attach **J** feet to **B** column leg with **K** (4) socket button head bolts, M6*20mm. Repeat with other leg.

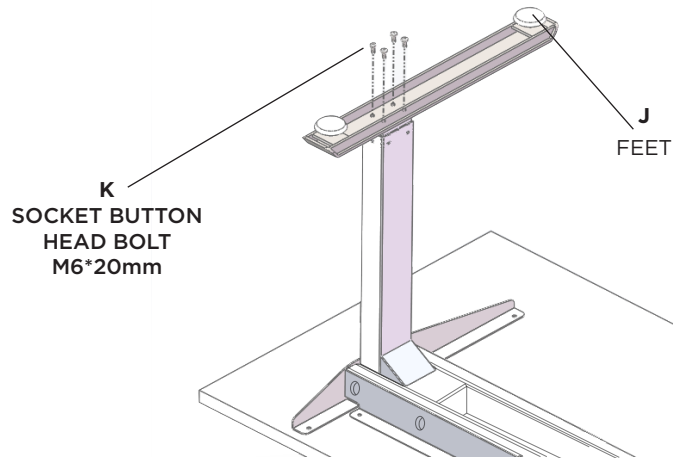

Step 6: Place both leg assemblies on worksurface and insert **E** center rails into **D** crossbeams as shown. Hole on center rails should be centered between crossbeams. Center leg assemblies on the worksurface. Make sure your overhang is even on both sides.

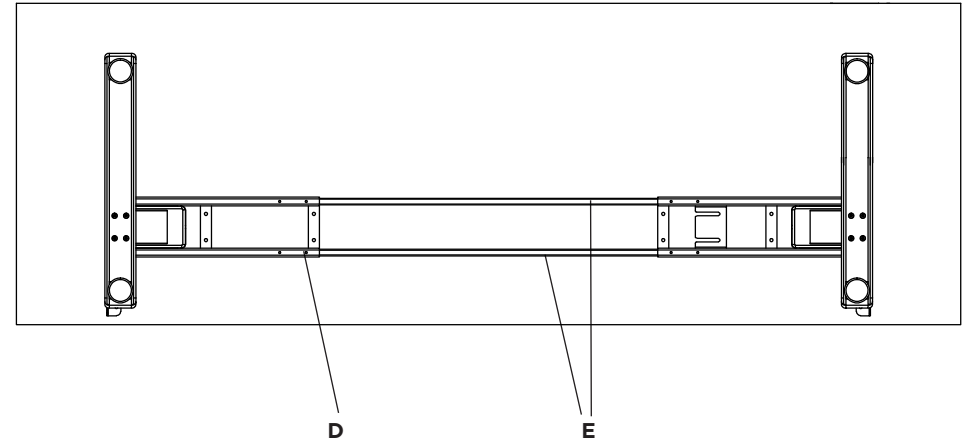

Base is: **A** - 38"-68"

D CROSSBEAM

E CENTER RAILS

- Maximum recommended top: 78" wide
- Minimum recommended top: 40" wide
- Install My-Hite tops 4" from the back of the base when using 29"+ depth tops is recommended.

Step 7: Secure **E** center rails to **D** crossbeams with **L** 8 socket button head bolt M6*12mm.

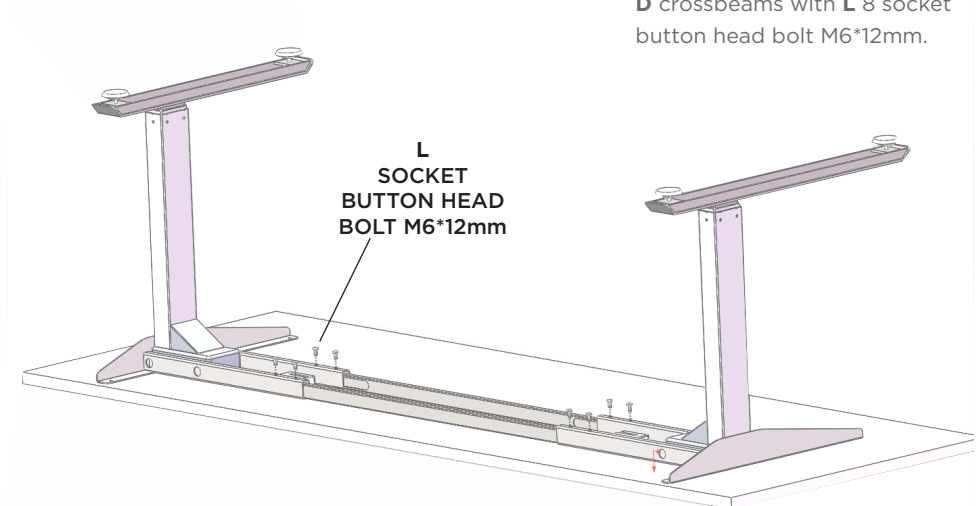

Installation Steps

Step 8: Ensure the leg assembly is still centered, both side-to-side and front-to-back. Secure the leg assembly to the worksurface with **N** (8) truss head screws M5*20mm.

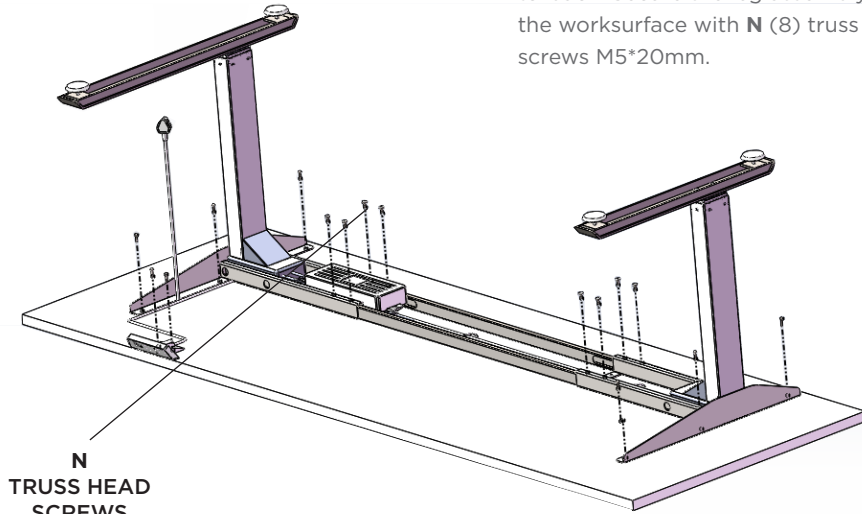

Step 9: Secure the side bracket to the worksurface with **N** (8) truss head screws M5*20mm.

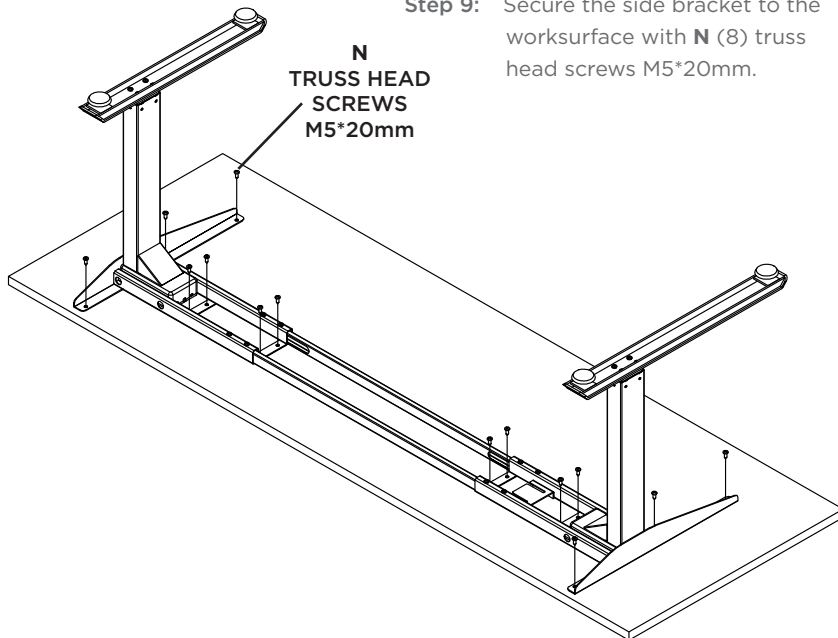

Step 10: Secure the **F** control panel in the desired location with **N** (2) truss head screws M5*20mm.

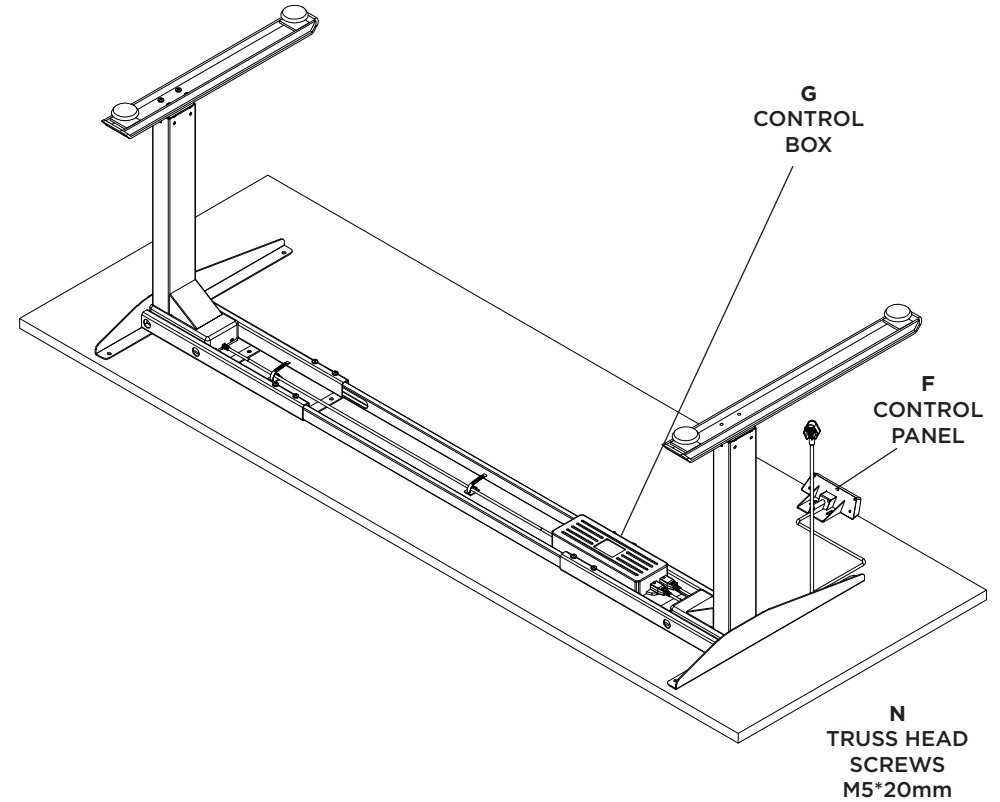

Step 11: Insert the **G** control box in-between crossbeam.

Installation Steps

Step 12: Connect **F** control panel to **G** control box with **I** connector wires as shown. Use **M** wire manager to secure **I** connector wires to underside of worksurface.

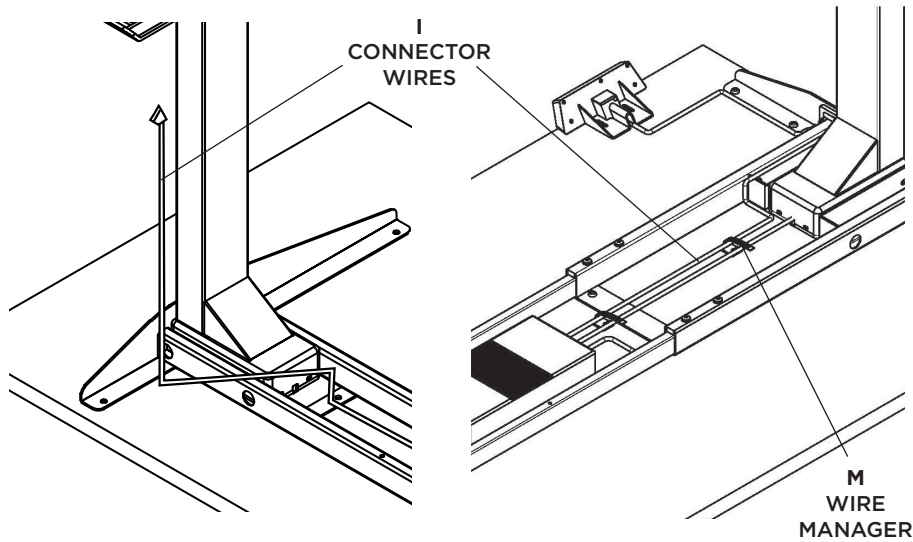

Schematic view of the My-Hite wiring:

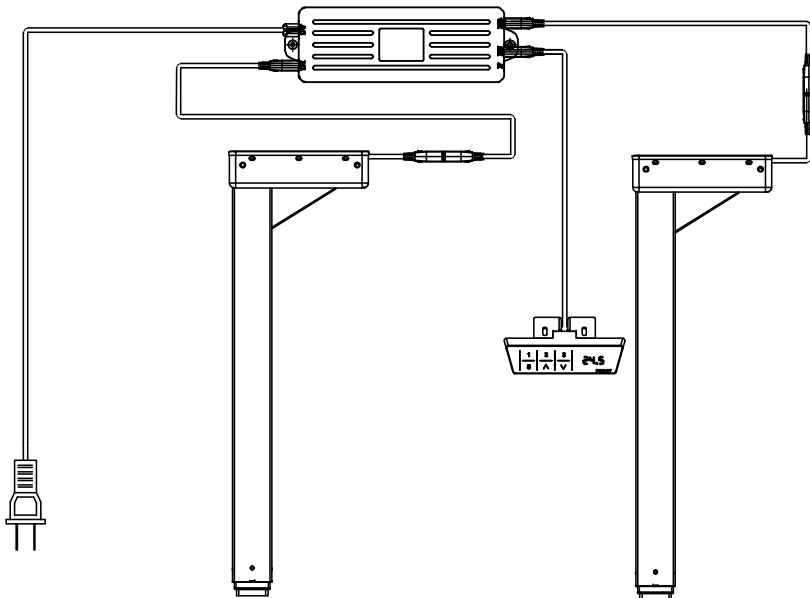

Step 13: Install the **H** telescopic cover plates, leaving exit space for the electrical power cords, and secure to worksurface with **N** (8) truss head screws M5*20mm

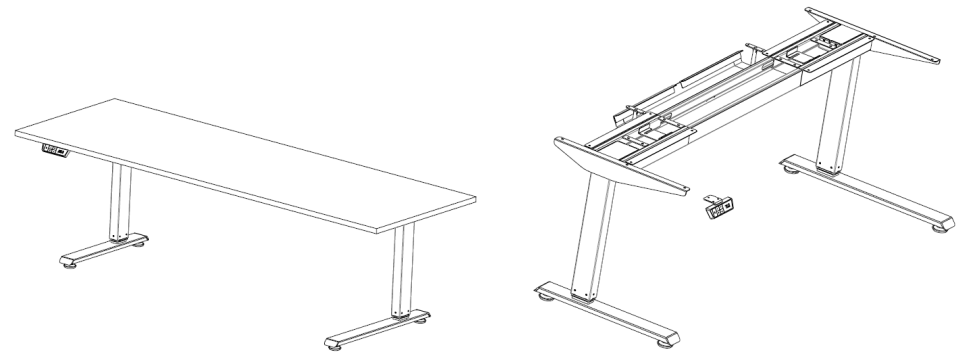
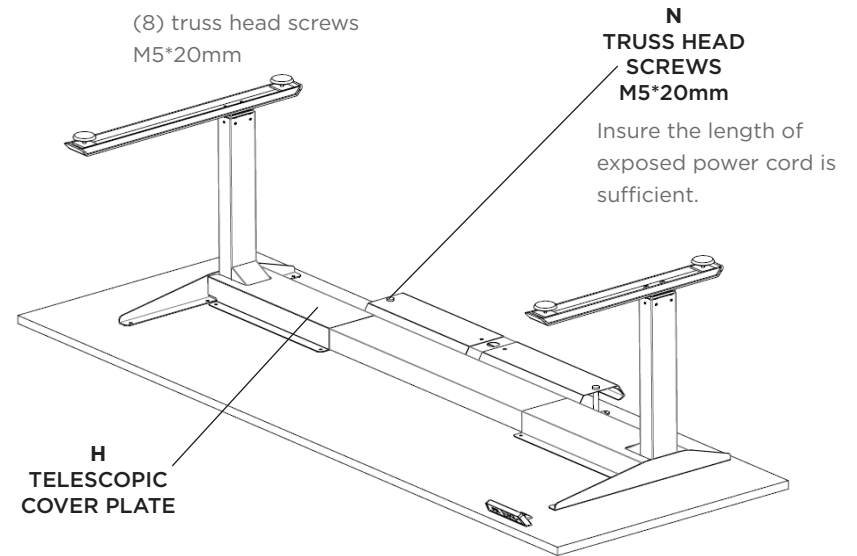

Step 14: Turn table right side up, adjust the glides as necessary, and plug the power cord into a 110v outlet.

Make sure the length of the plug-in cord is appropriate to both reach the outlet, AND for the distance the table will travel up and down. Range: 24.5" at lowest to 50" highest.

My-Hite 3 Stage Troubleshoot Reference

FIRST TIME USE

Step 17:

It is important to perform the reset operation below before you use your My-Hite table for the first time.

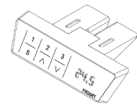

Reset Operation

1. Lower the table to 24.5" by holding arrow down (V) button. Release button.
2. Press the arrow down (V) button again and hold until ASR shows on the display.
3. Release the button and the ASR will flash on the display
4. Hold the arrow down button again. Table will shift up and down slightly as it resets to 24.5".

Note: If you cannot lower the table to the 24.5" height to perform reset operation, you may need to clear out the maximum and minimum height (See instructions on next page). Once completed, please return to the Reset Operation instructions.

General Tips

- Follow assembly instructions closely
- Do not overload the tables (220 lbs maximum straight, 330 lbs maximum corner)
- The input voltage should be within 108-132V
- Use the glides to properly level the table before use
- When moving the table, do not tilt the table on one leg or misalignment may occur
- Before first use, perform reset operation
- If, after trouble shooting the problem persists, contact Customer Success for further assistance.

Display in Centimeters

1. Press the arrow down (V) button until the display shows ASR.
2. Hold "2" button until the display shows "10.3"
3. Perform reset operation. After reset, the display will be in centimeters

Display in Inches

1. Press the arrow down (V) button until the display shows ASR.
2. Hold "2" button until the display shows "10.4"
3. Perform reset operation. After reset, the display will be in inches

TROUBLESHOOTING MY-HITE

Error code	Explanation	Cause	Solution
H01	Motor has overheated	Overuse	<ol style="list-style-type: none"> 1. Let motor rest for 10 minutes. 2. Perform reset operation . 3. If problem persists contact Friant Customer Success.
ERR, ASR or RST (solid or flashing)	System is locked	Various Reasons	<ol style="list-style-type: none"> 1. Remove plug from electrical outlet for 15 seconds, then plug unit back in. 2. Perform reset operation. 3. If problem persists contact Friant Customer Success to replace control panel.
No display	Control Panel has lost power	Disruption in power supply to base	<ol style="list-style-type: none"> 1. Remove plug from electrical outlet for 15 seconds, then plug unit back in. 2. Perform reset operation. 3. If problem persists contact Friant Customer Success to replace control panel.
E01, E02, or E03	Excessive weight distribution	Too much weight (limit exceeded) or Other problem	<ol style="list-style-type: none"> 1. Check that weight on table does not exceed limit. 2. Perform reset operation. 3. If problem persists contact Friant Customer Success to replace control panel.
E07, E08, or E09	Signal Interruption	Signal is interrupted between leg and computer	<ol style="list-style-type: none"> 1. Perform reset operation. 2. If problem persists contact Friant Customer Success
LOC	Locked display	Various Reasons	<ol style="list-style-type: none"> 1. Hold down "S" button for 10 seconds until display shows numbers indicating height 2. Display is now unlocked. 3. If problem persists contact Friant Customer Success

See next page for instructions on programming presets and for setting and clearing minimum and maximum heights

My-Hite 3 Stage Troubleshoot Reference

To Program The Memory Control Panel:

Adjust the table to the desired height, press the **S** key and one of the three preset buttons. This position is now saved. Once a preset button is pushed, the table will automatically move to the preset height. Repeat this procedure for each preset button.

Set Minimum Height (Version 1)

1. Press the arrow down (V) button to get to desired minimum height.
Note: the arrow down button must be the last button pressed to set the minimum height. You cannot press the arrow up button when trying to set the minimum height.
2. Hold "S" button until screen display flashes. Immediately press "S" button twice again.
3. Display will flash "000" and then show the set minimum height.

Set Maximum Height (Version 1)

1. Press the arrow up (Λ) button to get to desired maximum height.
Note: the arrow up button must be the last button pressed to set the maximum height. You cannot press the arrow down button when trying to set the maximum height.
2. Hold "S" button until screen display flashes. Immediately press "S" button twice again.
3. Display will flash "999" and then show the set maximum height.

Clear Maximum & Minimum Height (Version 1)

1. Table can be at **ANY HEIGHT** but **NOT** the minimum or maximum.
2. Hold "S" until display flashes. Release button.
3. Press "S" slowly, multiple times - until "555" shows on display.
Note: Display will show other codes, continue to press "S" until "555" shows.
4. Display will then show table height and can now move to any height between 24.5" and 50.1".

Special Clear Maximum & Minimum Height

Following is a special reset procedure when minimum and maximum height is set **within 1"** of each other:

1. Unplug unit for 10 minutes
2. Connect unit to power take care not to touch up or down arrows
3. Hold "S" button until it flashes
4. Let go and press "S" button 6 times in a row
5. 555 will show up on the display, minimum and maximum heights are now cleared.

Set Minimum Height (Version 2)

1. Press the arrow down (V) button to get to desired minimum height.
Note: the arrow down button must be the last button pressed to set the minimum height. You cannot press the arrow up button when trying to set the minimum height.
2. Press "S" button and then press down button.
3. Hold "S" button until screen display flashes "000".

Set Maximum Height (Version 2)

1. Press the arrow up (Λ) button to get to desired maximum height.
Note: the arrow up button must be the last button pressed to set the maximum height. You cannot press the arrow down button when trying to set the maximum height.
2. Press "S" button and then press up button.
3. Hold "S" button until screen display flashes "999".

Clear Maximum & Minimum Height (Version 2)

1. Table can be at **ANY HEIGHT** but **NOT** the minimum or maximum.
2. Press and release "S" button. Then hold "S" button until "555" shows on display.
3. Table can now move to any height between 24.5" and 50.1".

Adjust the Automatic Anti-collision Rebound Sensitivity

1. Press the arrow down (V) button to do the reset operation until ASR shows on the display.
2. Hold the arrow up (Λ) button for five seconds. The current sensitivity level will display:
10.5 for 20lbs, **10.6** for 30lbs, **10.7** for 40lbs
Note: Lower weight is more sensitive
3. To adjust, repeat this process to cycle through the sensitivity settings