

# MY-HITE ADJUSTABLE TABLE

## CORNER 2 STAGE T LEG BASE

Model Number : FCNAHBT-24-2

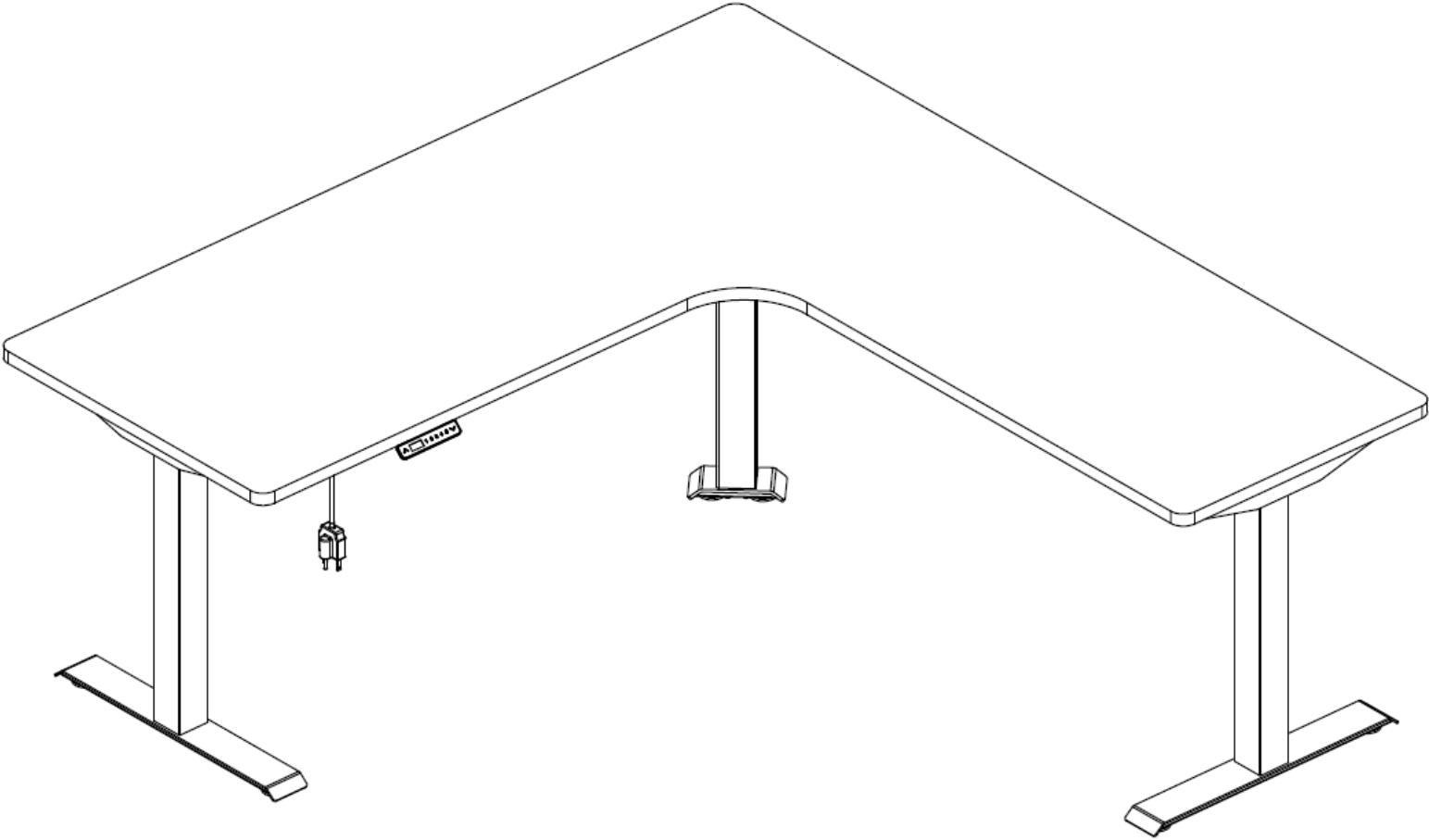

Please Read Instructions Before Use  
**ASSEMBLY INSTRUCTIONS**

Thank you for choosing Friant. We appreciate the trust and confidence you have placed in us and are committed to providing you the best possible product.

## Introduction

Friant offers a comprehensive line of office furniture for every space and requirement, now including My-Hite, a height adjustable table that allows for standing or sitting while working.

## User Notes

1. As with all power-operated products, please follow instructions closely and handle with care.
2. When moving My-Hite tables, please lift the tables, do not drag or tilt the table on one leg as misalignment may occur.
3. Check that the load on the table does not exceed limits (220lbs maximum on straight, 330lbs maximum on corner).
4. The input voltage should be within 108-132V.
5. Use the glides to properly level the table before use. Table should be level and aligned at all times.
6. Before first use, perform reset operation.
7. If, after trouble shooting the problem persists, contact Customer Service for further assistance.

**IMPORTANT:** When placing table in final location, be sure there is ample room for adjustment around ALL sides, and at the highest (45") and lowest (28") points the table can reach. Make sure table will not come into contact with any fixed objects (fixed tops, storage, shelving, etc.) while adjusting.

## Tools Needed



Single Sided  
Wrench



Socket Head  
Wrench

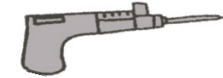

Electric Drill

**WARNING:** Failure to follow the assembly instructions in this manual can result in product damage, or personal injury.

Friant & Associates, LLC does not assume any responsibility for product that is altered in any way.

①























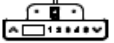

1. Read instructions carefully. Check that no parts are missing.

②



2. Carefully identify each component, especially those that are similar. The most common mistake is mixing up the order and placement of parts.

## Parts List

PART#	IMAGE	NAME	PIECES
A		Column Leg	3
B		Crossbeam	3
C		Pressure Retainer Lever	3
D		Pin	3
E		Mounting Plate	1
F		Connecting Rod Inner	2
G		Connecting Rod Outer	2
H		Connecting Beam	4
I		Holder	4
J		Feet	1
K		Feet	2
L		Control Box	1
M		Display	1
N		Metal Screw M6*15	8
O		Metal Screw M10*25	16
P		Wood Screws M5*20	22
Q		Socket Button Head Bolt M6*35	12
R		Wood Screw M5*25	2
S		Wood Screw with washer M3.5*15	2
T		Wood Screws M3.5*16	15
U		Wire Clips	15
V, W		Control Wires (3), Power Cord (1)	4

## Installation Steps

### Step 1

Place worksurface finished side down on a blanket.

### Step 2

Insert **A** column leg into **B** crossbeam assembly and slide back to lock into place. Repeat on other side.

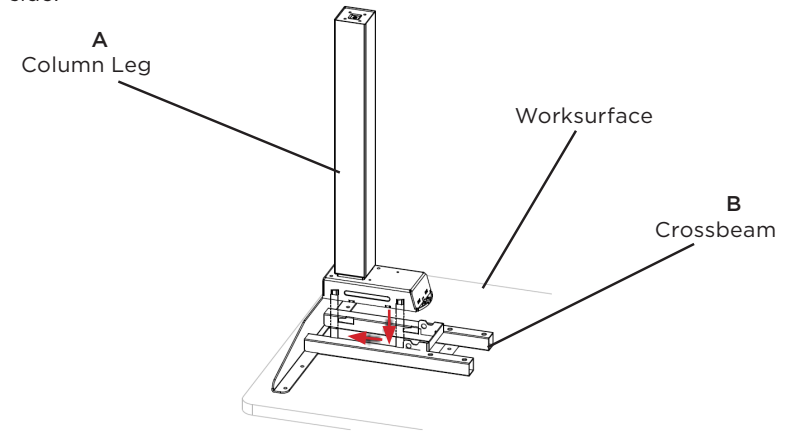

### Step 3

Insert **M** Pressure Retainer Lever into **B** crossbeam and insert **D** pin into **M** Pressure Retainer Lever, then rotate the lever to clamp **A** leg. Repeat on other side.

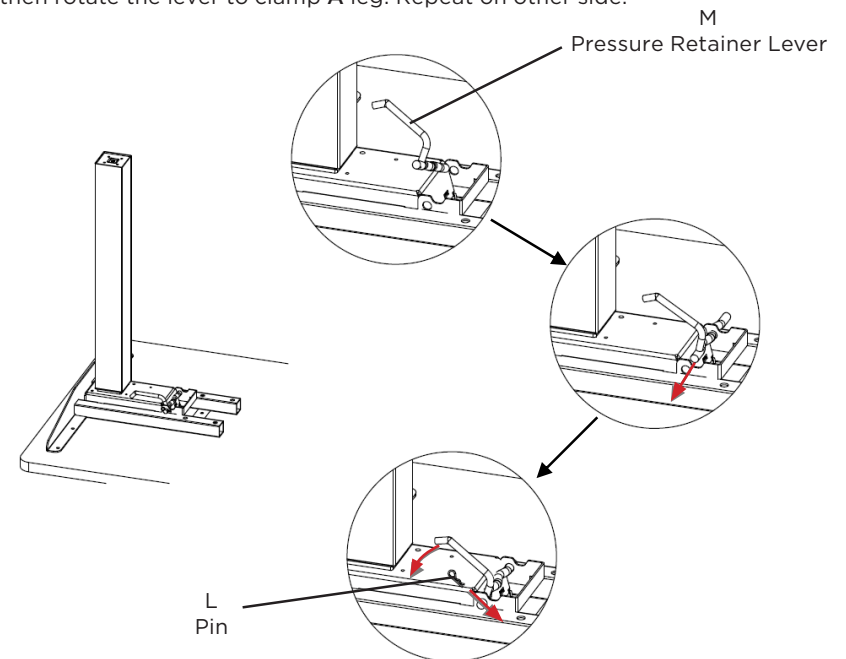

#### Step 4

Use (8) metal screws **N**, M6\*15mm to secure **E** mounting plate, **F** connecting rod inner and **G** connecting rod outer together as shown in detail. Then put **A** leg and **E** plate together like step 2 and step 3.

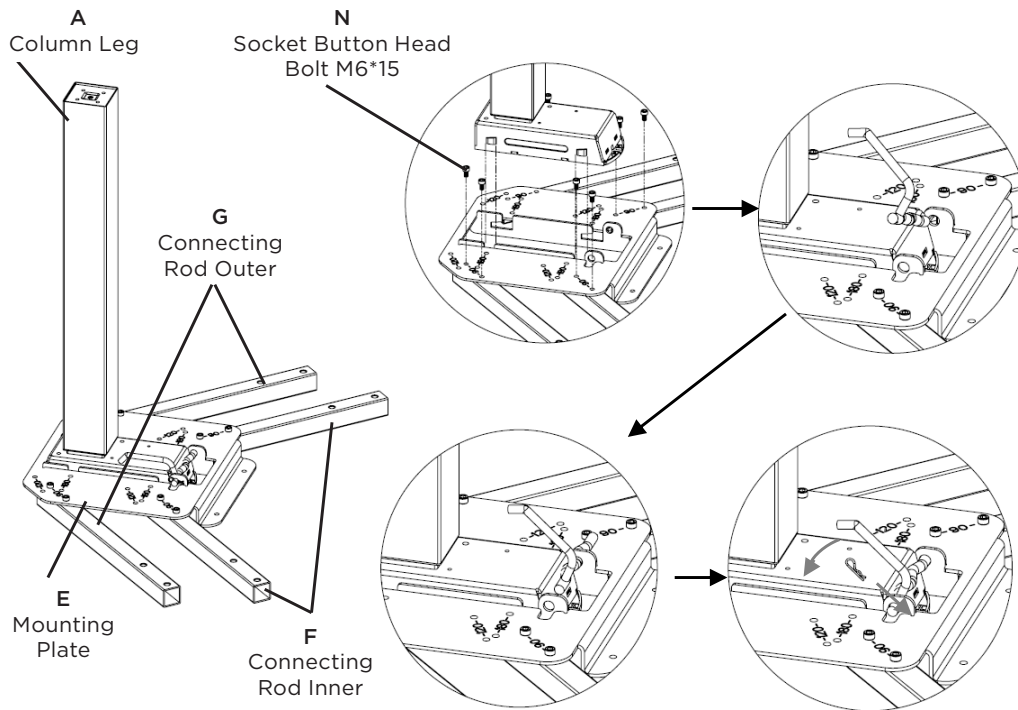

#### Step 5

Place all leg assemblies on worksurface and insert **H** connecting beams into **F** connecting rod inner, **G** connecting rod outer and **B** crossbeam, then use (16) flat screws **O**, M10\*25mm to secure crossbeams as shown. Hole on connecting beams should be centered between crossbeams. Center leg assemblies on the worksurface. Recommended A:0-19.5 in

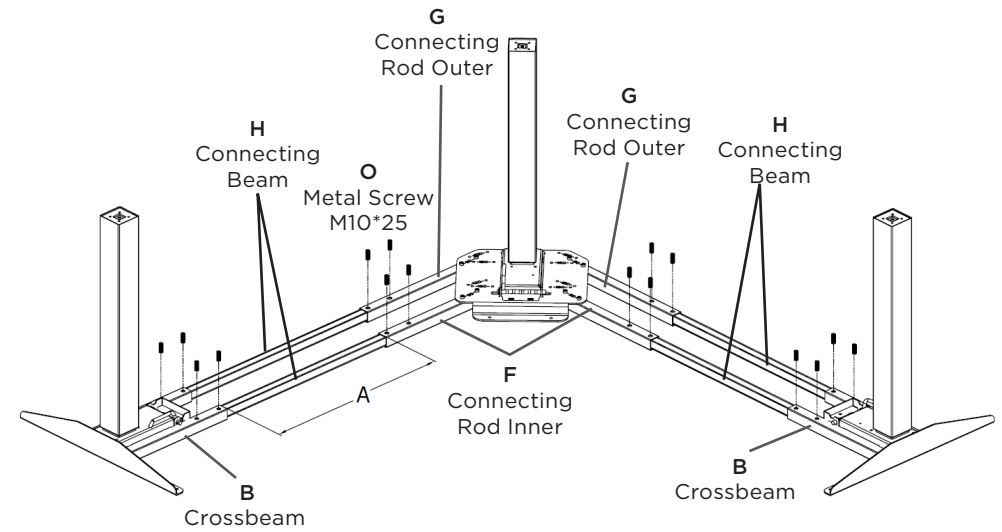

#### Step 6

Ensure two flanks of the leg assembly are still centered, both side-to-side and front-to-back. Put **I** holder on **F** connecting rod inner and **G** rod outer as shown. Secure the leg assembly to the worksurface with **P** (22) wood screws M5\*20.

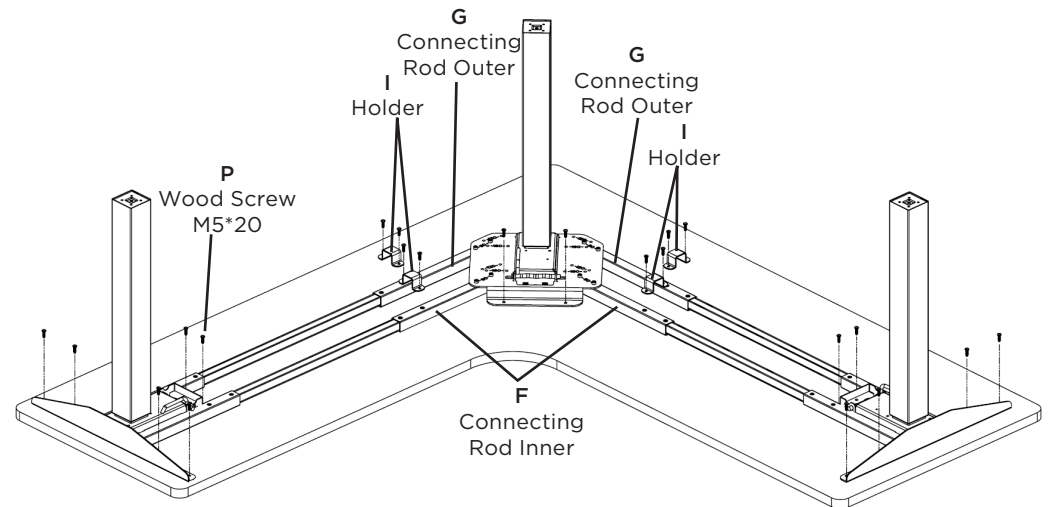

### Step 7

Attach **J** feet and **K** feet to **A** column leg with **Q** (12) socket button head bolts, M6\*35. Tighten bolts securely.

### Step 8

Secure **L** control box in the desired location with **R** (2) metal screws, M5\*25.

### Step 9

Secure **M** display in the desired location with **S** (2) wood screw with washers, M3.5\*15.

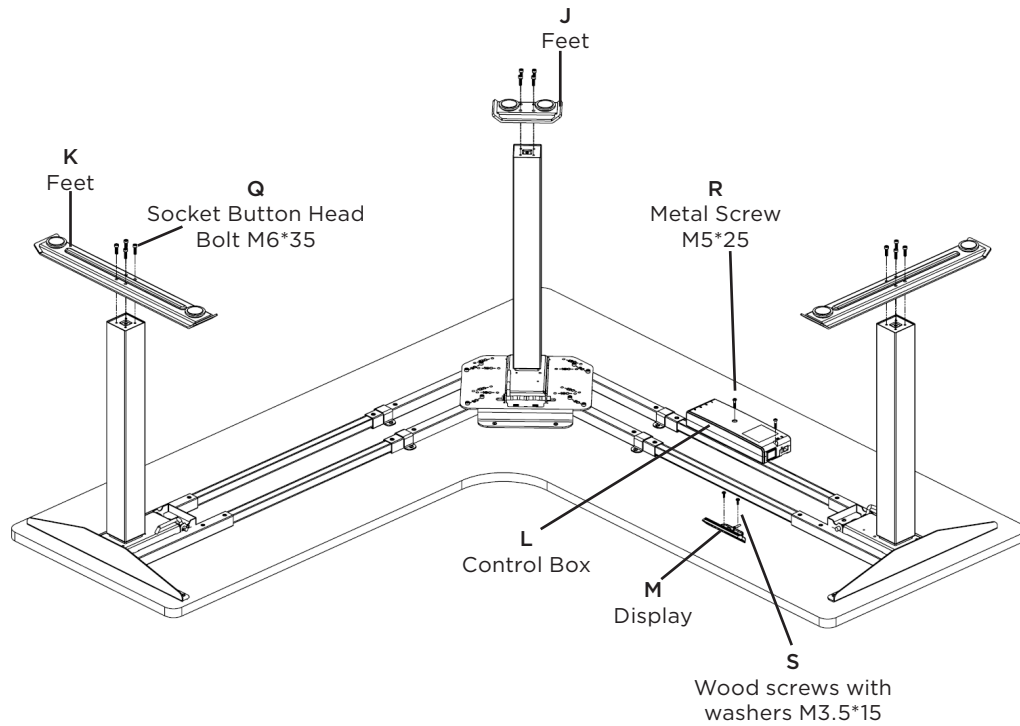

### Step 10

Connect **M** display and **A** column leg to **L** control box with **V** control wires as shown. Use **T** wood screws, M3.5\*16 and **U** wire clips to secure **V** control wires to underside of worksurface.

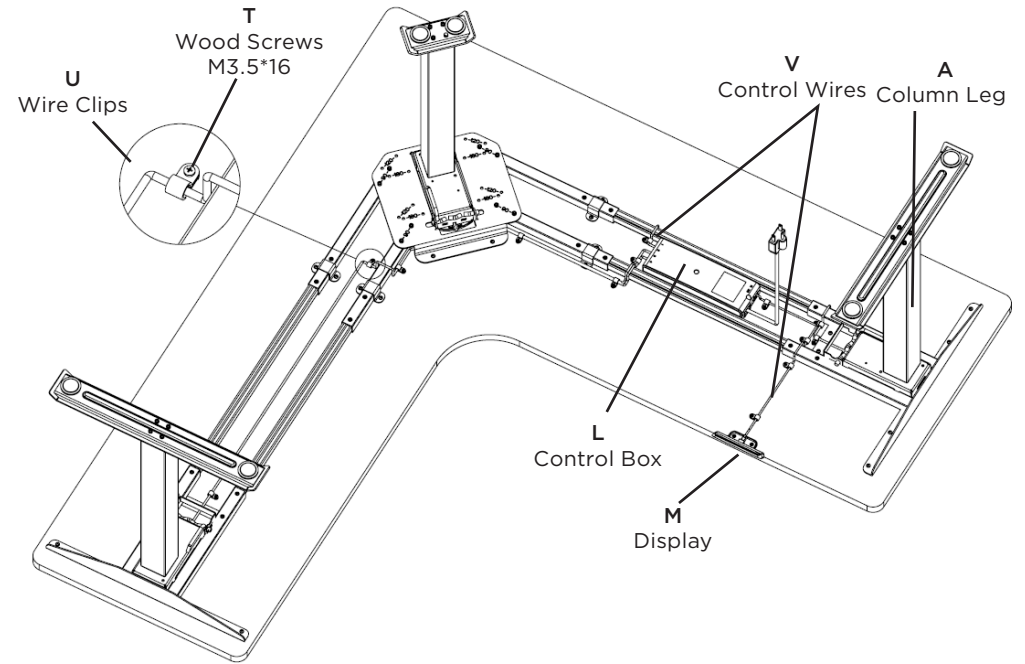

## Schematic view of My-Hite wiring

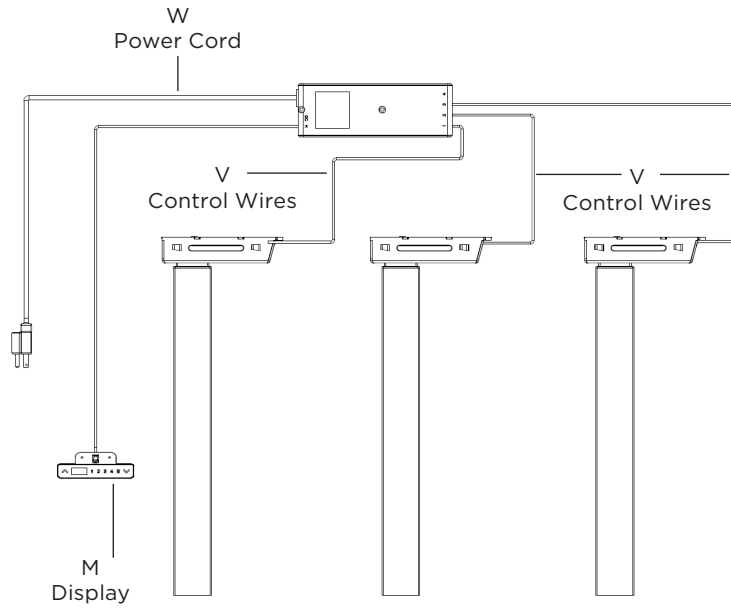

## Step 10

Turn table right side up, adjust the glides as necessary, and plug the power cord into a 110v outlet.

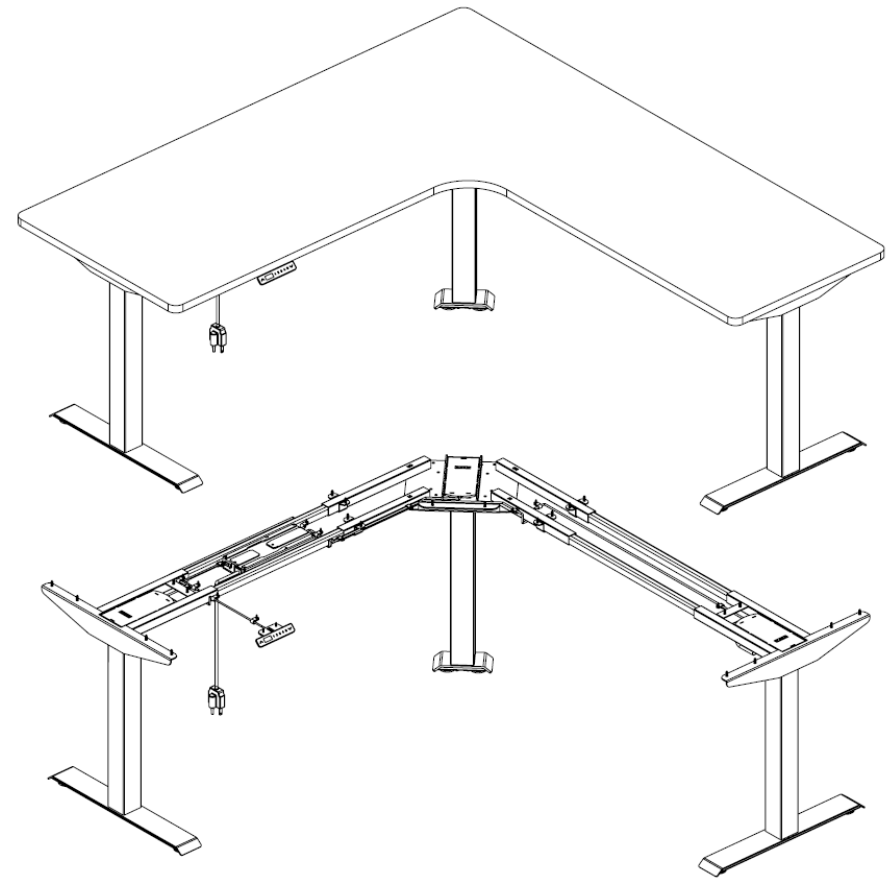

Make sure the length of the plug-in cord is appropriate to both reach the outlet, AND for the distance the table will travel up and down.  
Range: 28" at lowest to 45" highest.

## First Time Use:

Step 11:

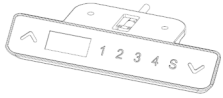

It is important to perform the reset procedure stated below before using your My-Hite table for the first time.

### 1) Reset Operation

1. Press and hold  $\wedge$  &  $\vee$  simultaneously for more than 3 seconds till legs begin to move down at half speed of normal operation.
2. Keep pressing buttons till legs move down to the lowest position and rebound 2-5 mm, then stop.
3. Release together. Reset is completed

### Notes:

- (a) The reset procedure must be completed after table is installed or parts replaced.
- (b) If reset process is interrupted, the system will stop running and will need to be reset to operate again.

### 2) Set Memory Position

1. Use  $\wedge$  &  $\vee$  buttons to adjust the table.
2. Press S, then press button 1 or 2 or 3 or 4 within next 3 seconds to set height for that #. Display position 1,2,3,4 is saved.

(c) After reset, memory settings need to be set again.

### 3) Removing Presets

1. Press and hold button S more than 10 seconds. Display will flash “— — —”
2. Release button S. Press button 1 within 3 seconds. The screen displays “H-0” which indicates that the presets are off. “H-1” indicates presets are on.
3. Press  $\wedge$  or  $\vee$  to change the current function of turn on or off.  
“H-0” - express function is off. “H-1” - express function is on.
4. Touch and hold button S for 2 seconds. Preset is on or off.

### 4) Set Maximum Height

1. Use  $\wedge$  &  $\vee$  buttons adjust table to desired maximum height.
2. Press and hold S, then press and hold 3 for about 3 seconds. Release. Letter “~L~” flashes on the screen. This means the table will not go above this height.

### 5) Set Minimum Height

1. Use  $\wedge$  &  $\vee$  buttons to adjust table to desired minimum height.
2. Press and hold S, then press and hold 1 for about 3 seconds. Release both buttons. Letter “\_L\_” flashes on the screen. This means the table will not go below this height.

### 6) Clear Minimum/Maximum Height

1. Press and hold S. Without releasing button S, press and hold 2 for 3 seconds.
2. Code “-C-” will clear.

### 7) Display in Inches or Centimeters

Press and hold S. Without releasing button S, press and hold  $\vee$  for 3 seconds. Release both buttons. The height information will toggle between inches and centimeters.

## Troubleshooting 2 stage My-Hite

Error Code	Explanation	Cause	Solution
E01	Connection Issue	The leg is disconnected from the control box.	Check the cable connections between leg and computer. Reset display. <b>If problem persists</b> contact Friant Customer Service.
E02	Continuous Operation	Continuous operation for 5 min.	Let motor rest for 10 min. Then try again. <b>If problem persists</b> contact Friant Customer Service.
E03	Tabletop Overload	The tabletop load exceeds the weight limit	Check that weight on table does not exceed weight limit. 2 stage straight - 220 lbs, 2 stage corner - 330 lbs <b>If problem persists</b> contact Friant Customer Service.
E04	Control Box Malfunction	Control Box Malfunction	Perform reset operation. <b>If problem persists</b> contact Friant Customer Service.
E05	Display is frozen	Display locked for 30 seconds	Perform reset operation. <b>If problem persists</b> contact Friant Customer Service.
E06	Communication Disconnected	Connection lost between display and control box	Check cables. Perform reset operation. <b>If problem persists</b> contact Friant Customer Service.
E07	Display shows less than 27"	The height on display is lower than 27"	Perform reset operation. <b>If problem persists</b> contact Friant Customer Service.
E08	Motor Short Circuit	Motor cable damaged	Check the motor cable for damage. <b>If problem persists</b> contact Friant Customer Service.
E09	Hall Error	Hall count error	Perform reset operation. <b>If problem persists</b> contact Friant Customer Service.
E10	Actuator Error	Failure of control box actuator	Disconnect power supply for 1 minute then plug in. <b>If problem persists</b> contact Friant Customer Service.
E11	Rebound Malfunction	Rebound function error	Perform reset operation. <b>If problem persists</b> contact Friant Customer Service.

### GENERAL TIPS

- Follow assembly instructions closely
- Do not overload the tables (220 lbs maximum straight, 330 lbs maximum corner)
- The input voltage should be within 108-132V
- Use the glides to properly level the table before use
- When moving the table, do not tilt the table on one leg or misalignment may occur
- Before first use, perform reset operation
- If after trouble shooting the problem persists, contact Customer Service for further assistance